

Climax S15V330S: Electric stacker

- Ergonomic compact pedestrian stacker
- Maintenance-free battery with on-board charger
- Creep speed function
- Ideal for applications in very confined spaces

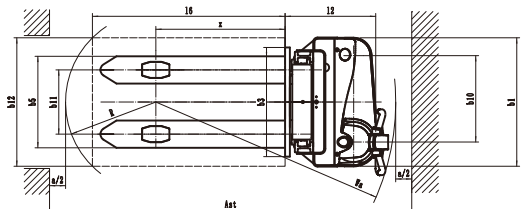

Characteristics			
1.2	Model designation		S15V330S
1.3	Drive unit		Battery
1.4	Operator type		Pedestrian
1.5	Load capacity	Q (kg)	1500
1.6	Load center	c (mm)	600
1.8	Load distance	x (mm)	805
1.9	Wheelbase	y (mm)	1240
Weights			
2.1	Service weight (Incl. battery)	kg	755
2.2	Axle loading, loaden operator/load side	kg	805/1450
2.3	Axle loading, unloaden operator/load side	kg	545/210
Wheels, Chassis			
3.1	Tyre type		PU/PU
3.2	Tyre size, operator side (diameter x width)	mm	Ø 230 x 75
3.3	Tyre size, load side (diameter x width)	mm	Ø 80 x 60
3.4	Balance wheels (dimensions)	mm	Ø 130 x 55
3.5	Wheels, number operator/load side (x = drive wheels)		1 x +2/4
3.6	Tread, operator side	b10 (mm)	538
3.7	Tread, load side	b11 (mm)	400
Dimensions			
4.2	Height, mast lowered	h1 (mm)	2128
4.3	Free lift	h2 (mm)	
4.4	Lift height	h3 (mm)	3300
4.5	Height, mast e x tended	h4 (mm)	3743
4.9	Height of tiller arm in operating position, min/max	h14 (mm)	1150/1480
4.15	Fork height, lowered	h13 (mm)	88
4.19	Overall length	l1 (mm)	1740
4.20	Length to face of forks	l2 (mm)	575
4.21	Overall width	b1/b2 (mm)	800
4.22	Fork dimensions	s/e/l (mm)	60/170/1150
4.24	Fork carriage width	b3 (mm)	680
4.25	Width across forks	b5 (mm)	570
4.32	Ground clearance	m2 (mm)	28
4.33	Aisle width, 1000 x 1200 pallet crossways	Ast (mm)	2340
4.34	Aisle width, 800 x 1200 pallet lengthways	Ast (mm)	2260
4.35	Turning radius	Wa (mm)	1500
Performance			
5.1	Travel speed, loaden/unloaden	km/h	5/5
5.2	Lifting speed, loaden/unloaden	m/s	0.13/0.2
5.3	Lowering speed, loaden/unloaden	m/s	0.13/0.13
5.8	Maximum gradeability, loaden/unloaden S2 5 min	%	8/16
5.10	Service brake		Elektromagnetic
Drive			
6.1	Drive motor rating S2 60 min	kW	1.27
6.2	Lift motor rating at S3 15%	kW	3
6.3	Maximum allowed size battery	mm	330/190/240
6.4	battery voltage/rated capacity	V/Ah	2 x 12/125
6.5	Battery weight (with box)	kg	2 x 30
	Battery type		Maintenance free battery
	Charger incorporated	V/A	24/15
Others			
8.1	Type of drive control		AC
10.5	Steering type		Mechanical
10.7	Sound level at operator's ear	dB (A)	74

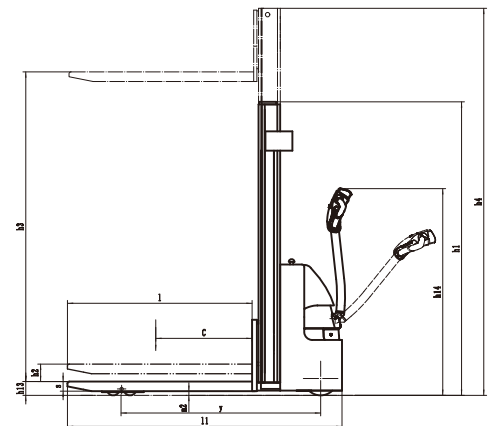

TVH* and Climax® are registered trademarks. © 04-2021, TVH Equipment NV, Brabantstraat 15, B-8790 Waregem. All rights reserved. No part of this publication may be reproduced or communicated in any form or by any means, electronic or mechanical, including copying, recording or use in an information storage or retrieval system, without prior and explicit permission of TVH Equipment NV.

ECBRSS_2101002

Climax®

info@climaxhandling.com · www.climaxhandling.com
TVH Equipment NV · Brabantstraat 15 · 8790 Waregem · Belgium