

# Climax S12V300: Electric stacker

- Creep speed function
- Long tiller offers easier operation
- Automatic switch to lower speed when forks reach setting height
- AC traction motor, maintenance-free

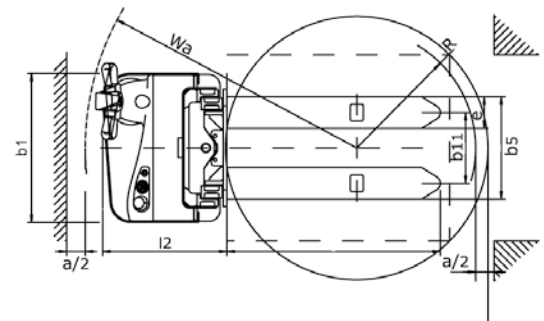

Characteristics			
1.2	Model designation		S12V300
1.3	Drive unit		Battery
1.4	Operator type		Pedestrian
1.5	Load capacity	Q (kg)	1200
1.6	Load center distance	c (mm)	600
1.8	Load distance, centre of drive axle to fork	x (mm)	688
1.9	Wheelbase	y (mm)	1315
Weights			
2.1	Service weight (Incl. battery)	kg	955
2.2	Axle loading, loaden operator/load side	kg	7515/1440
2.3	Axle loading, unladen operator/load side	kg	645/310
Wheels, Chassis			
3.1	Tyre type		PU/PU
3.2	Tyre size, operator side	mm	Ø 230 x 75
3.3	Tyre size, load side	mm	Ø 85 x 70
3.4	Balance wheels (dimensions)	mm	Ø 130 x 55
3.5	Wheels, number operator/load side (x = drive wheels)		1 x + 1/4
3.6	Tread, operator side	b10 (mm)	538
3.7	Tread, load side	b11 (mm)	380
Dimensions			
4.2	Height, mast lowered	h1 (mm)	1970
4.3	Free lift	h2 (mm)	100
4.4	Lift height	h3 (mm)	3000
4.5	Height, mast extended	h4 (mm)	3529
4.9	Height of tiller arm in operating position, min/max	h14 (mm)	715/1200
4.15	Fork height, lowered	h13 (mm)	88
4.19	Overall length	l1 (mm)	1826
4.20	Length to face of forks	l2 (mm)	676
4.21	Overall width	b1/b2 (mm)	800
4.22	Fork dimensions	s/e/l (mm)	60/170/1150
4.24	Fork carriage width	b3 (mm)	/
4.25	Width across forks	b5 (mm)	550
4.32	Ground clearance, center of wheelbase	m2 (mm)	28
4.33	Aisle width, 1000 x 1200 pallet crossways	Ast (mm)	2333
4.34	Aisle width, 800 x 1200 pallet lengthways	Ast (mm)	2303
4.35	Outer turning radius	Wa (mm)	1463
Performance			
5.1	Travel speed, loaden/unloaden	km/h	5/5.5
5.2	Lift speed, loaden/unloaden	m/s	0.10/0.16
5.3	Lowering speed, loaden/unloaden	m/s	0.19/0.18
5.8	Maximum gradeability, loaden/unloaden	%	16/8
5.10	Service brake		Electromagnetic
Drive			
6.1	Drive motor rating S2 60 min	kW	1.1
6.2	Lift motor rating at S3 15%	kW	2.2
6.3	Traction battery voltage/rated capacity	V/Ah	24/210
6.5	Battery weight (with box)	kg	190
	Battery type		Traction
	External charger	V/A	34/30
Others			
8.1	Type of drive control		AC
10.5	Steering type		Machanical
10.7	Sound level at operator's ear	dB (A)	74

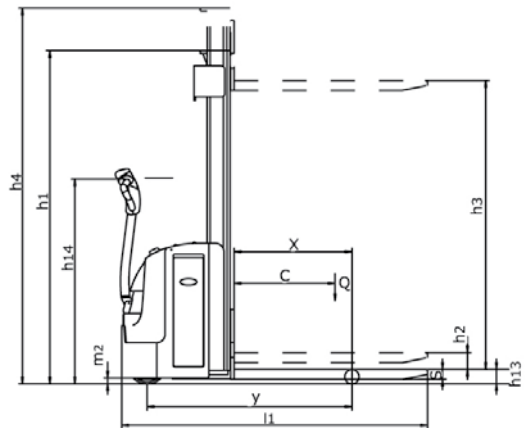

TVH\* and Climax® are registered trademarks. © 04-2021, TVH Equipment NV, Brabantstraat 15, B-8790 Waregem. All rights reserved. No part of this publication may be reproduced or communicated in any form or by any means, electronic or mechanical, including copying, recording or use in an information storage or retrieval system, without prior and explicit permission of TVH Equipment NV.

ECBRSS\_2101002

# Climax®

info@climaxhandling.com · www.climaxhandling.com  
TVH Equipment NV · Brabantstraat 15 · 8790 Waregem · Belgium