

Climax S12W420H: Electric stacker

- Enables the operator to pick up loads accurately and cautiously
- Operator-friendly tiller head with proportional control for improved load handling
- Controls positioned to allow operation with either hand
- Hour meter and battery discharge indicator with lift interrupt

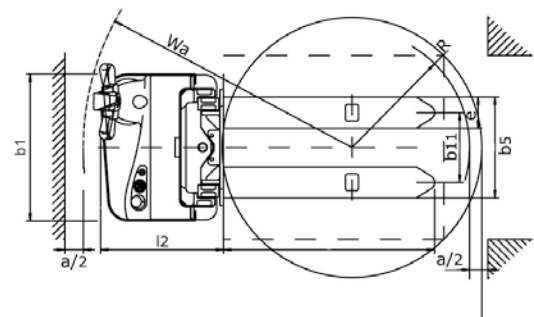

Characteristics			
1.1	Model designation		S12W420H
1.2	Drive unit		Battery
1.3	Operator type		Walkie
1.4	Load capacity	Q (kg)	1200
1.5	Load center	c (mm)	600
1.6	Load distance	x (mm)	700
1.7	Wheelbase	y (mm)	1218
Weights			
2.1	Service weight	kg	1175
2.2	Axle loading, loaden operator/load side	kg	750/1500
2.3	Axle loading, unloaden operator/load side	kg	715/335
Wheels, Chassis			
3.1	Tyre type		PU/PU
3.2	Tyre size, operator side (diameter x width)	mm	Ø 230 x 75
3.3	Tyre size, load side (diameter x width)	mm	Ø 85 x 70
3.4	Balance wheels (dimensions)	mm	Ø 85 x 50
3.5	Wheels, number operator/load side (x = drive wheels)		1 x + 1/2
3.6	Tread, operator side	b10 (mm)	538
3.7	Tread, load side	b11 (mm)	380
Dimensions			
4.1	Height, mast lowered	h1 (mm)	1922
4.2	Free lift	h2 (mm)	1490
4.3	Lift height	h3 (mm)	4200
4.4	Height, mast e x tended	h4 (mm)	4660
4.5	Height of tiller arm in operating position, min/max	h14 (mm)	825/1225
4.6	Fork height, lowered	h13 (mm)	85
4.7	Overall length	l1 (mm)	1826
4.8	Length to face of forks	l2 (mm)	676
4.9	Overall width	b1/b2 (mm)	800
4.10	Fork dimensions	s/e/l (mm)	60/170/1150
4.11	Outside fork width	b5 (mm)	550
4.12	Ground clearance	m2 (mm)	30
4.13	Aisle width, 1000 x 1200 pallet crossways	Ast (mm)	2370
4.14	Aisle width, 800 x 1200 pallet lengthways	Ast (mm)	2303
4.15	Outer turning radius	Wa (mm)	1463
Performance			
5.1	Travel speed, loaden/unloaden	km/h	5/5.5
5.2	Lifting speed, loaden/unloaden	m/s	0.127/0.15
5.3	Lowering speed, loaden/unloaden	m/s	0.23/0.22
5.4	Maximum gradeability, loaden/unloaden S2 5 min	%	8/16
5.5	Service brake		Electromagnetic
Drive			
6.1	Drive motor rating S2 60 min	kW	1.1
6.2	Lift motor rating at S3 15%	kW	2.2
6.3	Traction battery voltage/rated capacity	V/Ah	24/210
6.4	Battery weight (with box)	kg	205
6.5	Battery compartment dimensions l/w/h	mm	650/540/200
6.6	Battery type		Traction
Others			
7.1	Type of drive control		AC
7.2	Manufacturer		ZAPI
7.3	Sound level at operator's ear	dB (A)	74

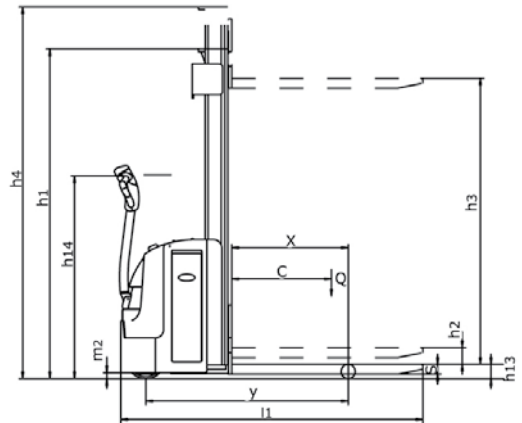

TVH* and Climax® are registered trademarks. © 12-2019 TVH Equipment NV, Brabantstraat 15, B-8790 Waregem. All rights reserved. No part of this publication may be reproduced or communicated in any form or by any means, electronic or mechanical, including copying, recording or use in an information storage or retrieval system, without prior and explicit permission of TVH Equipment NV.

E0BRDYV_1901002

Climax®

info@climaxhandling.com · www.climaxhandling.com
 TVH Equipment NV · Brabantstraat 15 · 8790 Waregem · Belgium